



Retrotouch[®]

Switches & Sockets



WIRING ACCESSORIES | SMART SWITCHES | PLUG SOCKETS

www.retrotouch.co.uk | sales@retrotouch.co.uk | Tel : +44 (0) 01293 279 426

Retrotouch®

Switches & Sockets

Retrotouch is a UK company that designs, and manufactures innovative switches & sockets for consumers, interior designers and developers. Founded in 2008, we are a team of designers and engineers. The consumer range is designed for the homeowner who wants the utmost in modern sophistication at a price which is affordable and easy installation and with design a priority.

Retrotouch products don't require expensive and time-consuming rewiring or complicated installations, and thanks to the continuity of the ranges, you can start small and add over time. With touch glass panels and surrounds, the switches and sockets bring a stylish finish to a room and give you the power to create ambience and mood lighting wherever and whenever you wish. There's no need for expensive controllers and transmitters as all of Retrotouch's light switches have the technology already built-in.

Our philosophy has always been that "We work forwards from what our customer needs are, and not backwards from what the technology allows. Everything we sell must be simple and intuitive to use for everyone from the installer to the whole family."



Co-Founders



PATENTED
PRODUCT



CUSTOMISATION
OPTIONS

NEW
PRODUCTS



Page 13-14



Page 15-18

RETROTOUCH IS LISTED ON:



CRYSTAL[®]

Switches & Sockets With A Touch Of Glass

LIGHT SWITCHES PAGE 5 - 10

SMART SWITCHES PAGE 13 - 20

DIMMERS PAGE 23 - 26

PLUG SOCKETS PAGE 29 - 32

WIRING ACCESSORIES PAGE 35 - 46

SIMPLICITY[™]

Premium Switches & Sockets

LIGHT SWITCHES PAGE 49 - 50

DIMMERS PAGE 51 - 52

PLUG SOCKETS PAGE 53 - 54

WIRING ACCESSORIES PAGE 55 - 56

HOTEL ACCESSORIES PAGE 57 - 58

PART M SWITCHES PAGE 59



AUGMENTED REALITY

See our switches and sockets on your wall.

Simply open your phone camera and scan the QR code anywhere you see the AR logo and follow the on-screen instructions



Try it now



Page 53-54



Page 35-36

*Retro*touch®
LIGHT SWITCHES

WITH A TOUCH OF GLASS™

CRYSTAL®

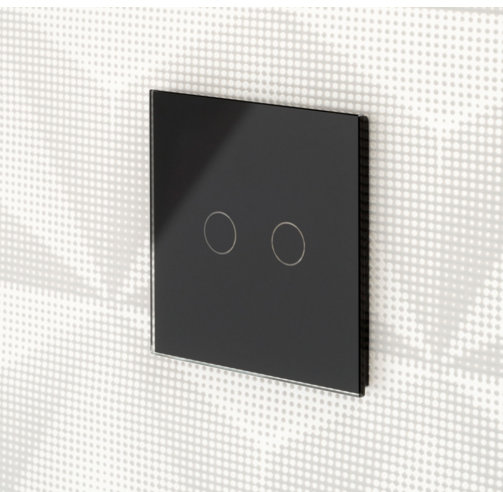

CRYSTAL TOUCH LIGHT SWITCHES

WITH A TOUCH OF GLASS™

NEW



TOUCH CONTROLLED.

Retrotouch Crystal Touch Light Switches are available in 1 to 3 gang options. With backlit LED touch areas, you can easily locate your switches at night. This model is available in four different colours and can be linked to 1-3 lights - whether your refurbishing or renovating, your interior will be brought up to date with our touch-sensitive switches.



SPECIFICATIONS / FEATURES

Our Crystal Touch model replaces the traditional light switch with a stunning LED indicator to bring your home up to date. These screwless covers are easy to install and fit a 35mm back box using standard wiring with no neutral required.

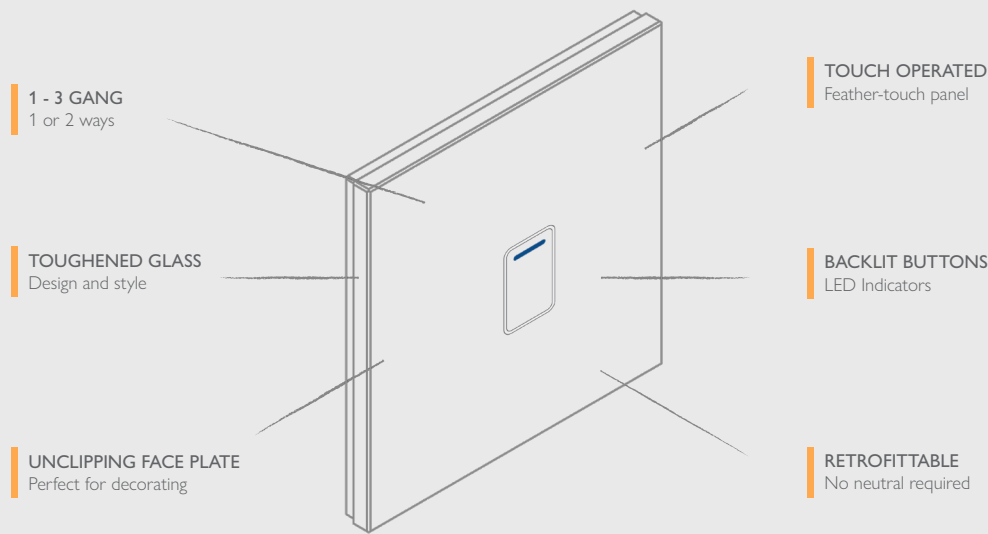

RETROFIT. NO NEUTRAL REQUIRED.

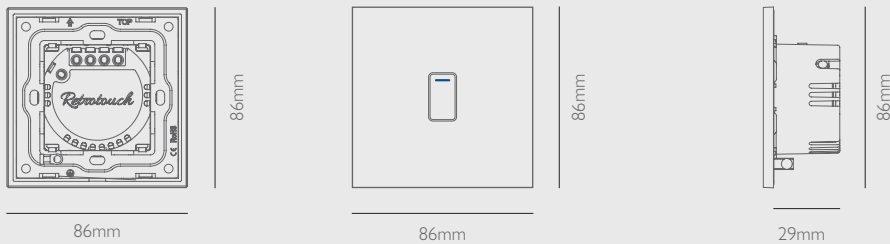

Features

Sophisticated glass finish

Adding a touch of glass for the ultimate finish

Touch Operation

Feather-touch panel with only the slightest of touches needed to turn on and off

Backlit LED indicators

The indicators glow blue when off and red when on for locating your switches in the dark

Fits 35mm back box

Offers quick and easy installation

Screwless fronts

The screws are hidden giving your switch a seamless design

Ultra-thin 4mm glass panel

Low profile panel that sits flush on your wall

Retrofit

No neutral required

What's in the box

Back plate with Module

Glass front plate in Black, White, Grey & Brass finish

2 screws for back box fixing

Instruction manual

Specifications

Voltage: 110 ~ 240V ~ 50/60HZ

Working Temperature: 0oC ~ 40oC Relative

Humidity: 10% - 93%

Energy Consumption: <0.02W

Measurement: 86 x 86 x 29mm

Backbox depth: 35mm

Life: 100,000 touches

Touch 1-3G 1WAY

Power Supply: 100 - 240V AC 50/60HZ

Load Power: 3 - 300W

Touch 1-3G 2WAY

Power Supply: 100 - 240V AC 50/60HZ

Load Power: 3 - 800W/G (2000W Max)

*Not all LED bulbs are compatible and depends on brand, please call for more information.

Certifications

2-year warranty

CE & RoHS certified

MODELS & FINISHES

WHITE PG TOUCH



ONE, TWO & THREE GANG

1G 1W: 01400 1G 2W: 01401

2G 1W: 01402 2G 2W: 01403

3G 1W: 01404 3G 2W: 01405

BLACK PG TOUCH

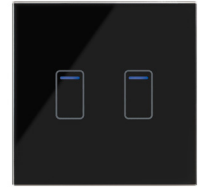

ONE, TWO & THREE GANG

1G 1W: 01406 1G 2W: 01407

2G 1W: 01408 2G 2W: 01409

3G 1W: 01410 3G 2W: 01411

GREY PG TOUCH



ONE, TWO & THREE GANG

1G 1W: 01412 1G 2W: 01413

2G 1W: 01414 2G 2W: 01415

3G 1W: 01416 3G 2W: 01417

BRASS PG TOUCH

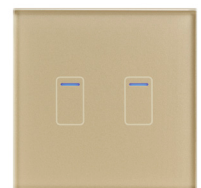

ONE, TWO & THREE GANG

1G 1W: 01418 1G 2W: 01419

2G 1W: 01420 2G 2W: 01421

3G 1W: 01422 3G 2W: 01423

Scan the QR code to view our new Touch Switch product page.



CRYSTAL®



ROCKER LIGHT SWITCHES

WITH A TOUCH OF GLASS™



TIMELESS. ELEGANT. DESIGN.

Our unique design features large easy to use switches, framed by an elegant combination of glass or glass with chrome trim. But that's not all, Retrotouch goes that extra mile and brings this together in a package that's so streamlined there isn't a screw in sight!



Retrotouch

+44 (0) 1293 279 426 | Sales@retrotouch.co.uk | Retrotouch.co.uk

SPECIFICATIONS / FEATURES

These Crystal Rocker Light Switches are a sophisticated way to revitalise the light switches in your home and modernise any interior.

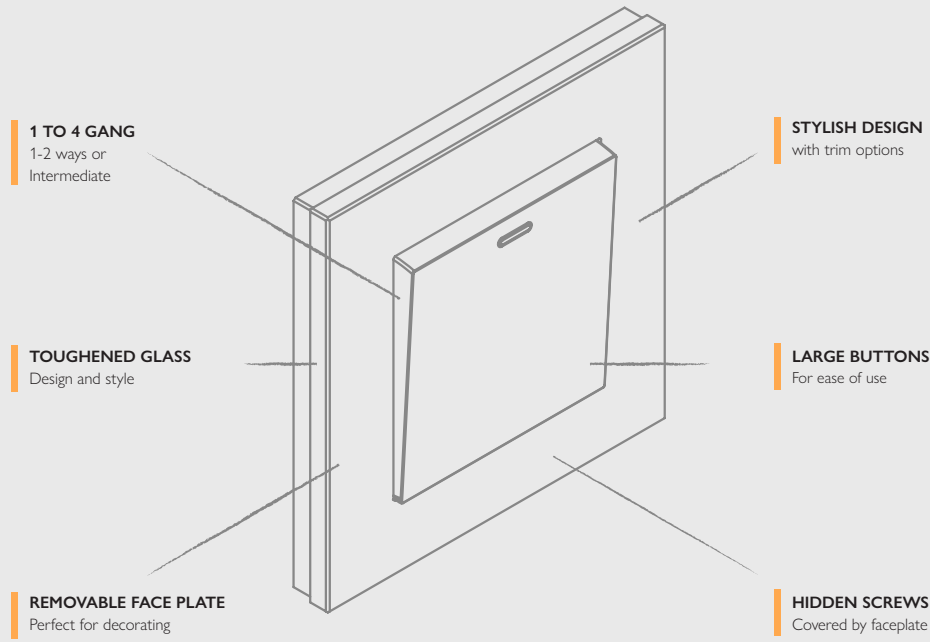

EASY INSTALL SYSTEM. SCREWDRIVER.

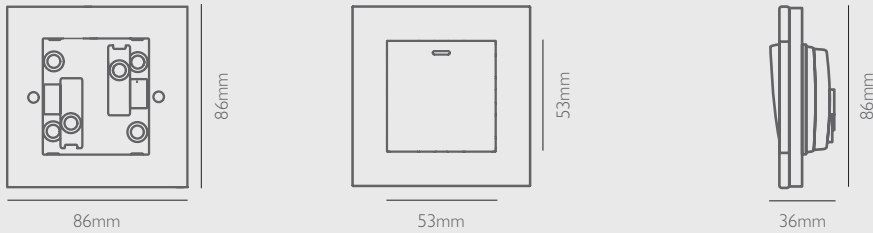

Features

- Sophisticated glass finish**
Adding a touch of glass for the ultimate finish
- Screwless fronts**
The screws are hidden giving your switch a seamless design
- Large easy press buttons**
Providing ease of use while keeping a premium look
- Fits 25mm back box**
Offers quick and easy installation

Specifications

- Rocker Mechanical Switch
- 1-4 gang (1 or 2 ways)
- 1-2 gang (Intermediate)
- 10 Amp Rated
- Glass Surround available with or without chrome
- Concealed Fixing Screws
- Fits in 25mm depth Back Box

What's in the box

- Back plate with Module
- Glass front plate in Black or White finish
- Screws for back box fixing x2
- Instruction manual

Certifications

- 10 Year Warranty
- BS60669
- CE & RoHS Certified

MODELS & FINISHES

ONE GANG



ONE WAY / TWO WAY

- PG: 00193 00202
- CT: 00191 00201

INTERMEDIATE

- PG: 00194 00204
- CT: 00192 00205

TWO GANG



ONE WAY / TWO WAY

- PG: 00213 00217
- CT: 00211 00221

INTERMEDIATE

- PG: 00214 00224
- CT: 00212 00222

THREE GANG



ONE WAY / TWO WAY

- PG: 00233 00243
- CT: 00231 00241

TWO GANG



ONE WAY / TWO WAY

- PG: 00252 00262
- CT: 00251 00261



Scan the QR code on your phone camera for augmented reality



CRYSTAL®

RETRACTIVE & PULSE SWITCHES

WITH A TOUCH OF GLASS™



12V & 240V MODELS AVAILABLE

These elegant retractive switches with spring loaded buttons are ideal for use with any home automation systems such as Fibaro, Loxone, Mode and many more.

You're free to control your Lights, Electric Blinds, Shutters, Garage Doors, Gates & more!

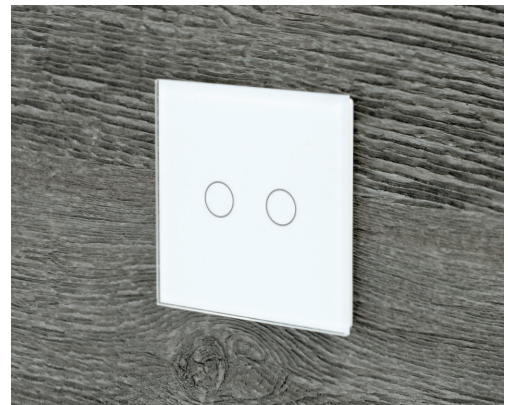

SPECIFICATIONS / FEATURES

Designed to work with all home automation systems, these mechanical or touch switches are easy to install and will look great in any interior. With screwless exteriors our models are designed to make your lighting system look as good as they function.

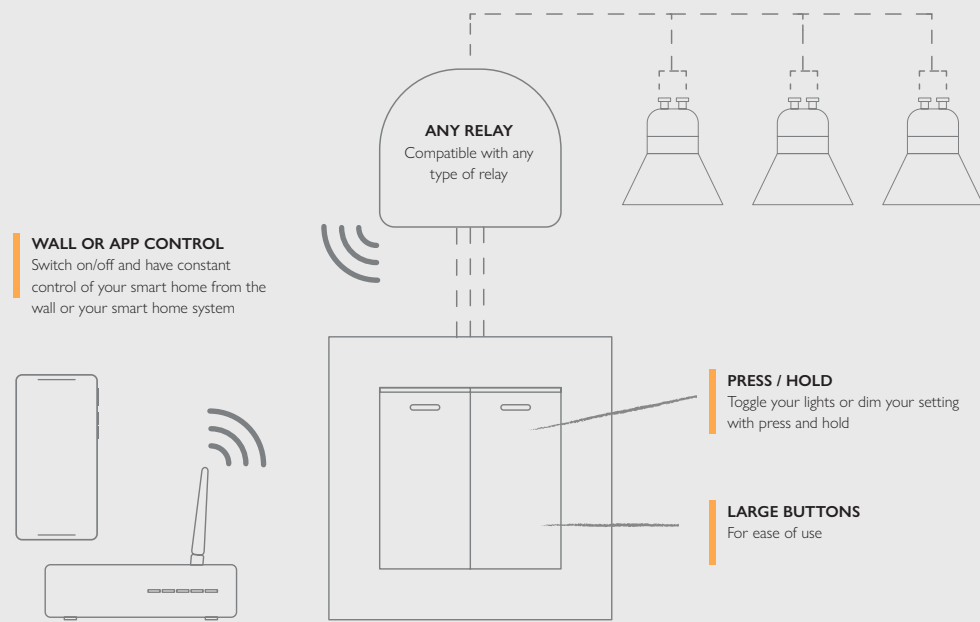

FOR HOME AUTOMATION SYSTEMS.

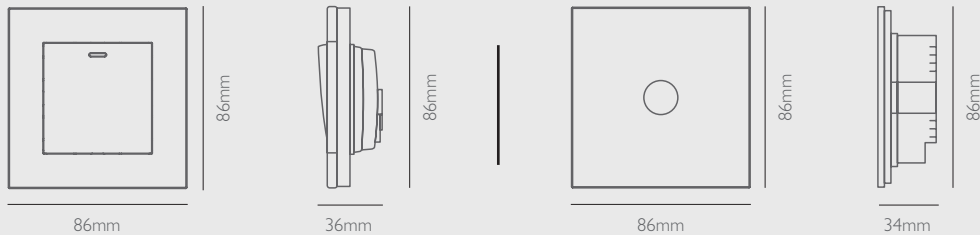

Features

Retractive / Pulse switch

A quick, easy and affordable way to modernise either your current home, business, hotel or project.

Screwless fronts

The screws are hidden giving your switch a seamless design

Sophisticated glass finish

Adding a touch of glass for the ultimate finish

Backlit LED indicators (Touch version)

The indicators glow blue when off and red when on for locating your switches in the dark

Ultra-thin 4mm glass panel

Low profile panel that sits flush on your wall

Specifications

Glass Surround with Chrome trim versions

Concealed fixing screws

86 x 86mm (Standard Single)

Rated Voltage: 220~240V AC (50/60Hz)

Operating Power: 3W - 1000W

Working Temperature: 0°C~40°C

Relative Humidity: 10% - 93%

Energy Consumption: <0.02W

Rocker

1-4 Gang (Controls 1-4 Lights)
Fits In 25mm Depth Back Box (Rocker Version)

Touch

1-3 Gang (Controls 1-3 Lights)
Blue glow for easy night use
Fits In 35mm Depth Back Box (Touch Version)

What's in the box

Retractive switch with glass plate in Black or White finish

2 screws for back box fixing

Instruction manual

Certifications

2 Year Warranty

CE & RoHS Certified

MODELS & FINISHES

ONE GANG



ROCKER / TOUCH

PG:		00196		00197
CT:		00198		00199
12V:		02012		02018

TWO GANG



ROCKER / TOUCH

PG:		00219		00218
CT:		00220		00223
12V:		02014		02020

THREE GANG



ROCKER / TOUCH

PG:		00239		00238
CT:		00240		00245
12V:		02022		02016
240V:		00492		00495

FOUR GANG



PULSE / RETRACTIVE

PG:		00259		00258
-----	--	-------	--	-------



Scan the QR code on your phone camera for augmented reality



*Retro*touch®
SMART SWITCHES

WALL. APP. VOICE. SMART.

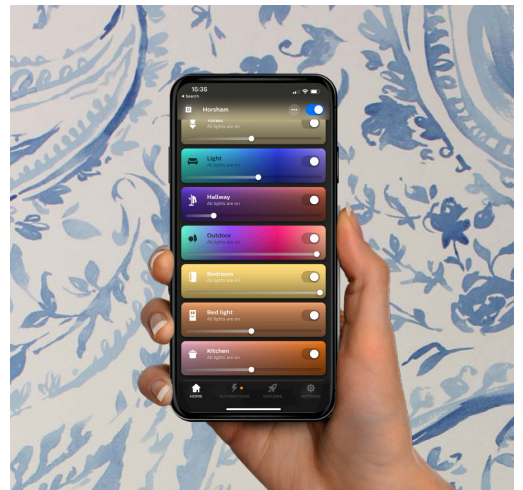

CRYSTAL+

NEW

SMART WI-FI SWITCHES

WITH A TOUCH OF GLASS™

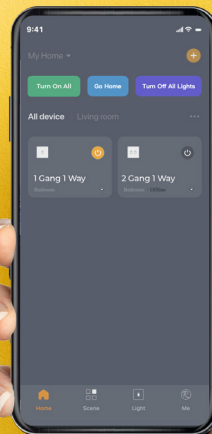
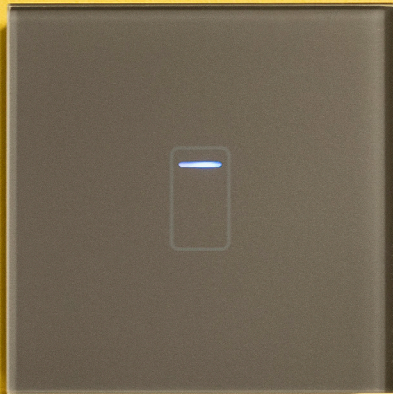

SMART CONTROL.

Our Crystal Touch WiFi Switches have a sophisticated glass finish and backlit LED indicators have been integrated to help locate your switches in the dark. You have the option of managing your lighting via our Smart App or you can connect to your Amazon Alexa or Google Mini for voice control services.

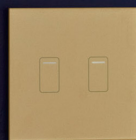

SPECIFICATIONS / FEATURES

Our Crystal Smart model replaces the traditional light switch with a stunning LED indicator to bring your home or business up to date. These screwless covers are easy to install and fit a 35mm back box using standard wiring.

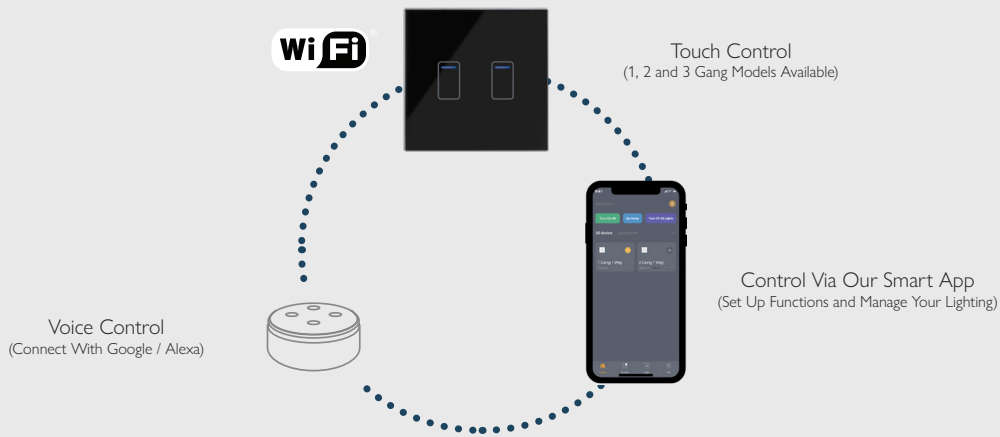

RETROFIT. NO NEUTRAL REQUIRED.

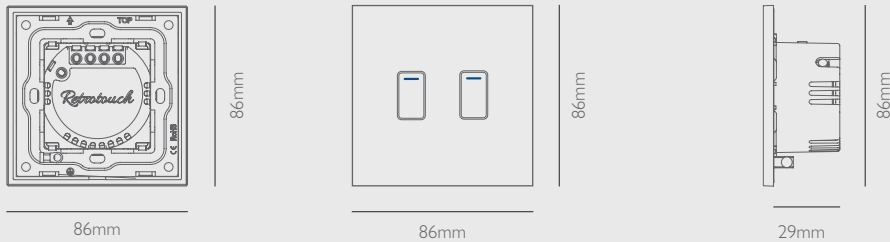

Features

Sophisticated glass finish

Adding a touch of glass for the ultimate finish

Touch Operation

Feather-touch panel with only the slightest of touches needed to turn on and off

App Control

Manage your lighting with our App

Voice Control

Connect to your Amazon Alexa

Backlit LED indicators

The indicators glow soft blue when off and bright blue when on for locating your switches in the dark

Fits 35mm back box

Offers quick and easy installation

Screwless fronts

The screws are hidden giving your switch a seamless design

Specifications

Voltage: 110 ~ 240V ~ 50/60HZ

Working Temperature: 0oC ~ 40oC Relative

Humidity: 10% - 93%

Energy Consumption: <0.02W

Measurement: 86 x 86 x 35mm

Backbox depth: 35mm

Life: 100,000 touches

Power Supply: 100 - 240V AC 50/60HZ

Load Power: 3 - 800W/G (2000W Max)

Certifications

2-year warranty

CE & RoHS certified

What's in the box

Back plate with Module

Glass front plate in Black, White, Grey & Brass finish

2 screws for back box fixing

Instruction manual

MODELS & FINISHES

WHITE PG TOUCH



ONE, TWO & THREE GANG

1G: 01450 2G: 01451

3G: 01452

BLACK PG TOUCH

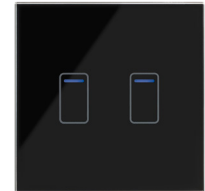

ONE, TWO & THREE GANG

1G: 01453 2G: 01454

3G: 01455

GREY PG TOUCH



ONE, TWO & THREE GANG

1G: 01456 2G: 01457

3G: 01458

BRASS PG TOUCH



ONE, TWO & THREE GANG

1G: 01459 2G: 01460

3G: 01461

Scan the QR code to view our new Wi-Fi Smart Switch product page.





FRIENDS OF HUE SMART SWITCHES

WITH A TOUCH OF GLASS™



SWITCHES FOR HUE.

Retrotouch has become an official supplier of Philips Hue light switches, working together to provide consumers with a beautifully-designed 'always on' system for effortless control over their Philips Hue lighting.

Addressing the issue of a homes wireless smart lighting connections being cut off from smart functions, if a light switch is manually switched off, the new Retrotouch switches ensure that the lighting circuit is always on. While the switches will work as normal to flip lights on and off, the lighting circuit will remain on so that Hue is always ready and working when you want it, seamlessly delivering smart App, HomeKit and motion functions.



SPECIFICATIONS / FEATURES

Seamlessly integrate with the Phillips Hue lighting system, this switch is the missing piece of the Hue system jigsaw for a user experience that works from wall, voice, motion or app.



ALWAYS ON HUE EXPERIANCE.

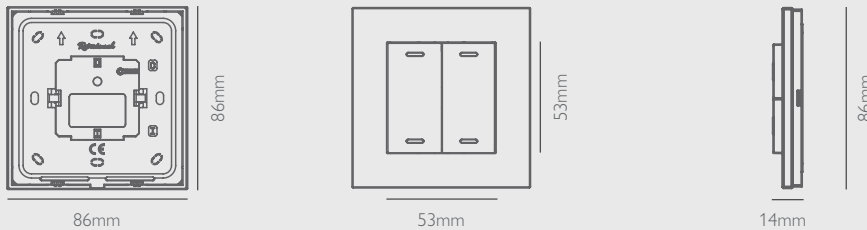

Features

- Wireless, stick-anywhere, battery-free switch**
Can control up to 50 Philips Hue lights and lamps simultaneously from a Hue hub.
- Ensures that the Hue lighting system is always-on**
no more having to leave a light switch on for the lamps to have power and hue system work.
- Switch connects directly to the Philips Hue Bridge**
No additional Smart Home Hub is needed.
- Stylish, premium glass design**
to perfectly complement the smart Philips Hue system
- Certified Friends of Hue**
Compatible and certified to work with all Philips Hue lighting
- Works with Apple Homekit**
Compatible with Apple HomeKit via Hue Bridge. Take control of your home from your walls.

What's in the box

- Back plate with Module
- Glass front plate in Black or White finish
- 2 Button & 1 Button included
- 3M Wall sticky pad
- 2 screws for back box fixing
- Terminal connector block for retrofit applications
- Instruction manual

Specifications

- Indoor Range: Up to 20m
- Outdoor Range: Up to 300m
- Material: ABS & Toughened Glass
- Frequency: Zigbee, 2.4Ghz
- 86 x 86 x 14mm (Standard Single)
- 2 Button (4 channels) & 1 Button (2 channel)
- Operational temperature: 0°C to 40°C
- Altitude: 2000m
- Limited Warranty: 2 Year

Certifications

- Europe, CE & RoHS Certified**
EN 60950-1:2006+A11:2009+, A1:2010+A12:2011+A2:2013
EN 301489-3 V1.6.1, EN 61000-3-2:2013, EN 61000-3-3:2013, EN 300220-2V3.1.1, EN 62479:2010,
- USA, FCC & IC Rules**
- Hue, Friends of Hue, and all related logos are trademarks of Signify Holding, Philips is a trademark of Koninklijke Philips N.V.

MODELS & FINISHES

PLAIN GLASS



ONE & TWO GANG

- PG: 02802 02803
- CT: 02800 02801

ALSO AVAILABLE

SMART BUTTON PLATE FOR PHILIPS HUE BUTTON



ONE & TWO GANG

- PG: 02832 02833
- CT: 02830 02831

Plate Features

- Sophisticated Glass Finish
- Stick Anywhere
- Magnetic Connection
- Replace Your Existing Switch
- Always On Hue system



OPEN YOUR PHONE CAMERA & SCAN THE QR CODE FOR AUGMENTED REALITY



iOS 13+, iPADOS 13+ or Android with ARCore 1.9+ required

Battery-free
by EnOcean

WIRELESS KINETIC SWITCHES

WITH A TOUCH OF GLASS™



WIRELESS. BATTERY-FREE. TIMELESS.™

The Retrotouch EnOcean switches don't require batteries or a power cable and they are as durable and reliable as a traditional wired switch. Thanks to EnOcean's innovative harvesting technology, each press of the switch generates enough energy to send a radio signal to a relay for a totally wireless and robust control solution.



SPECIFICATIONS / FEATURES

Powered by EnOcean's energy harvesting technology, each press of the switch generates enough energy to send a radio signal to a relay for a totally wireless and battery-free solution.

EnOcean Fused with Retrotouch Design

Design Details

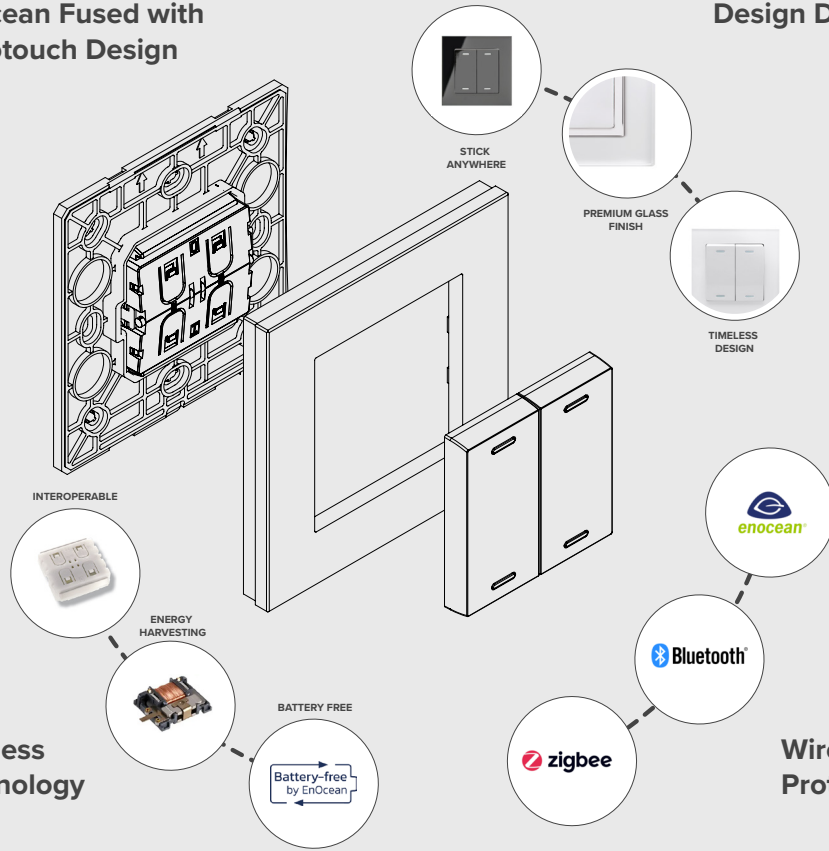

Wireless Technology

Wireless Protocols

THE FUTURE OF LIGHTING CONTROL.

Features

- High quality toughened glass**
Available as plain glass or with a chrome trim finish
- Batteries not required**
Kinetic powered switch
- Wireless operation**
Control your lighting / smart system with set functions
- Mount anywhere**
Using included 3M sticky pad
- Multi-Function Buttons**
Individual press and hold actions
- Retrofit on any UK or European standard back-box**
Fixing screws and terminal connector block included

Specifications

- 2 Button (4 channels) & 1 Button (2 channel)
- Kinetic powered By EnOcean Technology
- Operational temperature: 0°C to 40°C
- Altitude: 2000m
- Dimensions: 86*86*14mm
- Limited Warranty: 2 Year

Module Protocols Available

- EnOcean™
- BLE™
- ZigBee™
- Friends of Hue™

What's in the box

- Back plate with Module
- Glass front plate in Black or White finish
- 2 Button & 1 Button
- 3M Wall sticky pad
- 2 screws for back box fixing
- Terminal connector block for retrofit applications

Certifications

- Europe**
EN 60950-1:2006+A11:2009+, A1:2010+A12:2011+A2:2013, EN 301489-3 V1.6.1, EN 61000-3-2:2013, EN 61000-3-3:2013, EN 300220-2:V3.1.1, EN 62479:2010
- USA**
FCC & IC Rules

MODELS & FINISHES

BLUETOOTH®



ONE & TWO GANG

- PG: 02622 02623
- CT: 02620 02621

ZIGBEE



ONE & TWO GANG

- PG: 02642 02643
- CT: 02640 02641

ENOCEAN



ONE & TWO GANG

- PG: 02602 02603
- CT: 02600 02601

PART-M



ONE & TWO GANG

- PG: 02677

iOS 13+, iPADOS 13+ or Android with ARCore 1.9+ required

SPECIFICATIONS / FEATURES

Control your lighting and other devices via an EnOcean smart home system. Wirelessly connect our switches to the relay and convert any powered device into a smart device which you can control from your phone or smart hub.

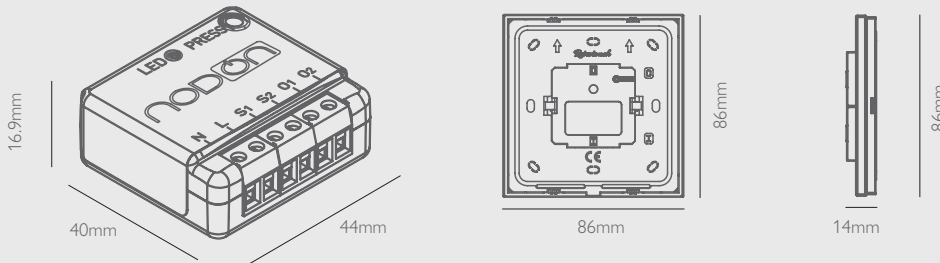
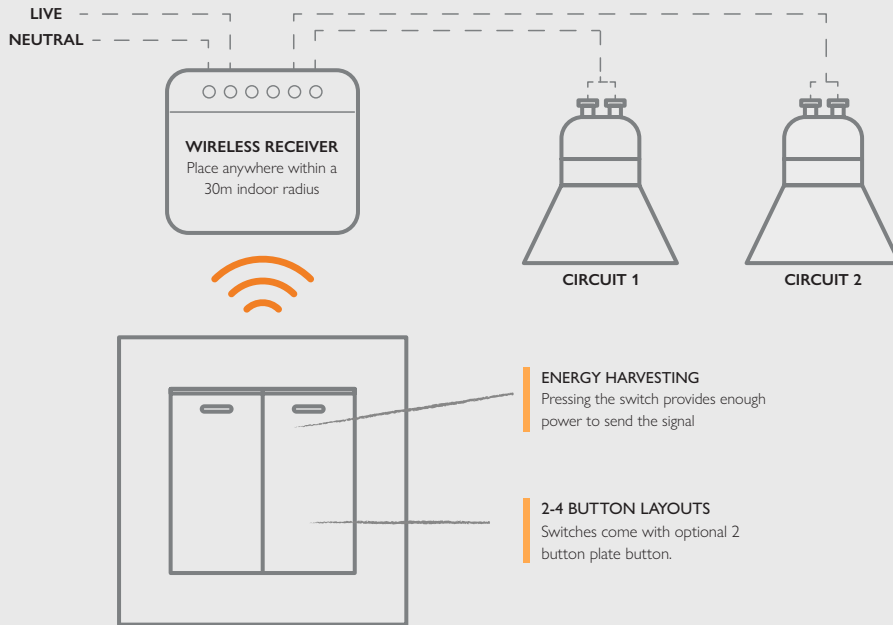

MOST ADVANCED ENOCEAN RELAY.

Specifications

- Power supply : 230V AC ~ 50Hz
- Switching capabilities: 230V AC – 2 x 5A
- Consumption: <1W
- Radio frequency range: 868,0 to 868,6 Mhz
- RF power max: +3dBm
- Range: Up to 30m inside
- Operational temperature: 0°C to 40°C
- Protection rating: IP 2X
- Pairing: up to 22 controllers
- EEP (EnOcean Profile): D2-01-12
- Dimension: 40 mm (l) x 44 mm (L) x 16.9 mm (h)

Certifications

- EN60669-1:1999+A1:02+A2:08
- EN60669-2-1:2004+A1:09+A12:10
- EN300220-2 V3.1.1
- EN301489-01 V2.1.1
- EN301489-03 V2.1.1
- EN62479:2010

What's in the box

- EnOcean relay module
- Quick connector
- User guide

ENOCEAN KINETIC SWITCHES

ENOCEAN



ONE & TWO GANG

- PG: 02602 02603
- CT: 02600 02601

LIGHTING RELAY

ON/OFF



SIN-2-2-01

POWER RELAY

MULTIFUNCTION



SIN-2-1-01

Relay Features

Power supply: 230V AC ~ 50Hz
Range: Up to 30m inside

ENOCEAN SWITCH ANDRECEIVER STARTER KIT

STARTER KIT



Starter Kits:

- B-EN-M-B-CT-NOD
- B-EN-M-W-CT-NOD
- B-EN-M-B-PG-NOD
- B-EN-M-W-PG-NOD
- B-EN-S-B-PG-NOD

Bluetooth® KOZEE WIRELESS RELAYS

SPECIFICATIONS / FEATURES

The Kozee receiver can control two lighting circuits - you can control these circuits from the wall using a Retrotouch Bluetooth Smart Switch via the Kozee App or voice control from Alexa. It can be wired discreetly into any household LED light system.

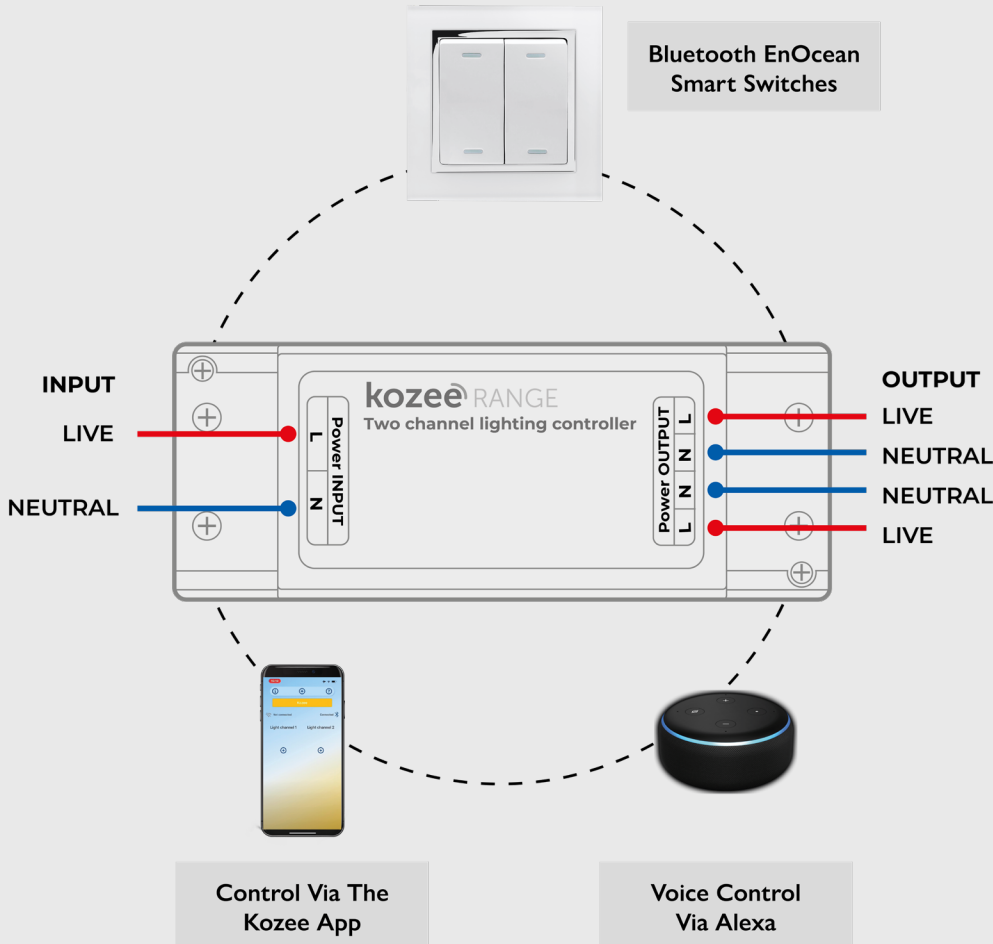

CONTROL WITH APP & VOICE.

Specifications

- Input: Voltage Range 220-240VAC - Frequency 50HZ
- Max Mains Current: 1.4A
- Output: Channel 1 120W max / Channel 2 120W max
- Radio transmitter: WiFi IEEE802.11 b/g/n, BLE
- Operating Frequency: 2.4Ghz Transceiver
- Max Output Power: 120W per Channel
- Operating Temp: 20°C + 45°C
- Max Relative Humidity: 0-80%
- Connections: 0.5 - 1.5mm AWG
- Mechanical Dimensions: H30mm X W45mm X L115mm
- Weight: 68g
- Protection Rating: IP20 (indoor use only)
- Range: 10m Clear Air, 8m Indoor (dependent on barriers)

Features

- 2 Channel 120W Receiver
- Bluetooth and Wifi
- Works with Alexa Voice Control (WiFi Version)
- Works with Retrotouch Bluetooth Smart Switch

What's in the box

- EnOcean relay module
- Quick connector
- User guide

BLUETOOTH KINETIC SWITCHES

BLUETOOTH



ONE & TWO GANG

- PG: 02602 02603
- CT: 02600 02601

LIGHTING RELAY

ON/OFF



BT-RC2C/DWIFI

Relay Features

Control your switches via the wall, the Kozee App or even through Alexa.

Maximum output power: 120W per channel

BLUETOOTH WIRELESS SWITCH AND RECEIVER STARTER KIT

STARTER KIT



Starter Kits:

- B-EN-M-B-CT-KOZ
- B-EN-M-W-CT-KOZ
- B-EN-M-B-PG-KOZ
- B-EN-M-W-PG-KOZ
- B-EN-S-B-PG-KOZ

For videos & image gallery visit our website.



Retrotouch[®]

DIMMERS

SETTING THE MOOD.

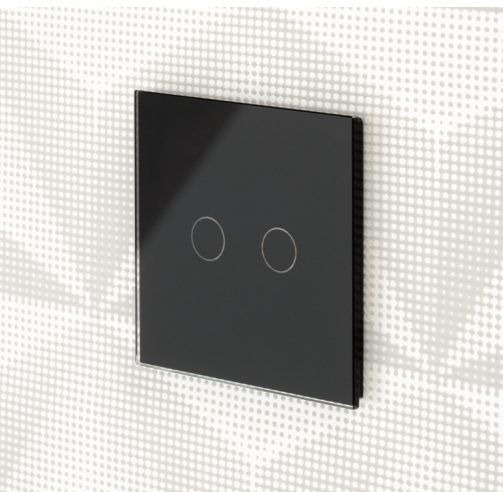

CRYSTAL

NEW

TOUCH & WI-FI DIMMER SWITCHES

WITH A TOUCH OF GLASS™

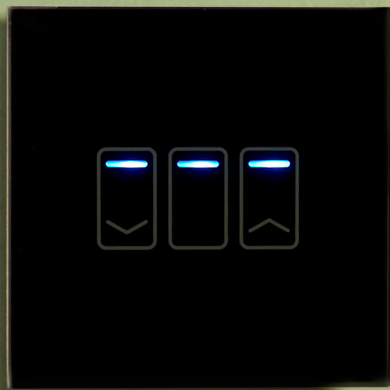

LATEST DIMMING TECHNOLOGY.

Our Touch Dimmer switches come in four different colours - Black, White, Grey and Brass - 1 to 2 gang model options are available. These beautifully simple devices glow blue when off, to allow for easy night time use. Our units are designed to work with LED bulbs.



SPECIFICATIONS / FEATURES

Our Crystal Touch Dimmer switches replace the traditional dimmer model with stunning LED indicators to bring your home or business up to date.

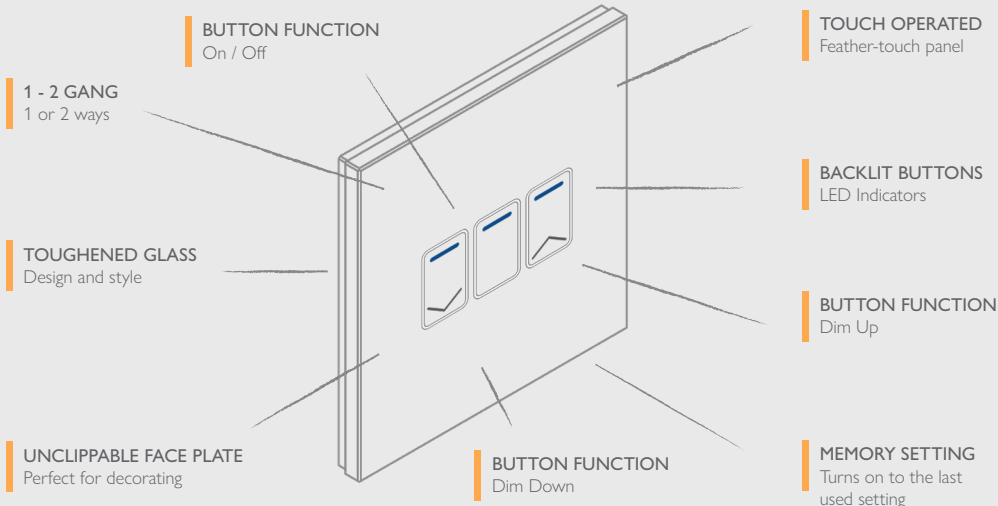

TOUCH & HOLD TO DIM.

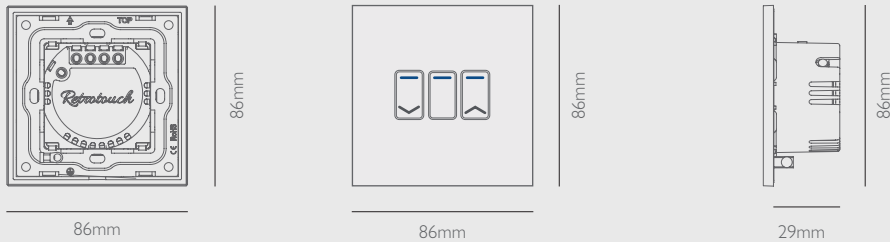

Features

Sophisticated glass finish

Adding a touch of glass for the ultimate finish

Touch Operation

Feather-touch panel with only the slightest of touches needed to turn on and off

Backlit LED indicators

The indicators glow soft blue when off and bright blue when on for locating your switches in the dark

Fits 35mm back box

Offers quick and easy installation

Screwless fronts

The screws are hidden giving your switch a seamless design

Leading-edge dimming

Our dimmers use the latest dimming technology

Wi-Fi Dimmer

App Control

Manage your lighting with our App

Voice Control

Connect to your Amazon Alexa

What's in the box

Back plate with Module

Glass front plate in Black, White, Grey & Brass finish

2 screws for back box fixing

Capacitors included (DIMMER ONLY)

Instruction manual

Specifications

Voltage: 110 ~ 240V ~ 50/60HZ

Working Temperature: 0oC ~ 40oC Relative

Humidity: 10% - 93%

Energy Consumption: <0.02W

Measurement: 86 x 86 x 29mm

Backbox depth: 35mm

Life: 100,000 touches

Touch Dimmer

Power Supply: 100 - 240V AC 50/60HZ

Load Power: 3 - 200W (10 Lamps Max)

Note: Our dimmer switches are not suitable for use with fluorescent loads, including energy saving lamps and certain non dimming LED bulbs.

*Not all LED bulbs are compatible and depends on brand, please call for more information.

Certifications

2-year warranty

CE & RoHS certified

MODELS & FINISHES

WHITE PG TOUCH



ONE & TWO GANG (TOUCH)

1G: 01430 2G: 01431

ONE GANG (WI-FI)

1G: 01480

BLACK PG TOUCH

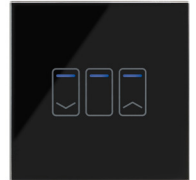

ONE & TWO GANG (TOUCH)

1G: 01432 2G: 01433

ONE GANG (WI-FI)

1G: 01481

GREY PG TOUCH



ONE & TWO GANG (TOUCH)

1G: 01434 2G: 01435

ONE GANG (WI-FI)

1G: 01482

BRASS PG TOUCH



ONE & TWO GANG (TOUCH)

1G: 01436 2G: 01437

ONE GANG (WI-FI)

1G: 01483

Scan the QR code to view our new Touch Switch product page.



CRYSTAL®



ROTARY DIMMER SWITCHES

WITH A TOUCH OF GLASS™



LIGHTS. DIM. ACTION.

Retrotouch's dimmer switch collection features a premium glass design, making your home both timeless and elegant. Designed for dimming LED's, they use the latest in trailing edge dimming technology to create an appealing ambience to any interior.



SPECIFICATIONS / FEATURES

Set the mood for your home with our dimmer plates. Our plates boast a premium glass design with a smoothly adjustable dimming knob.

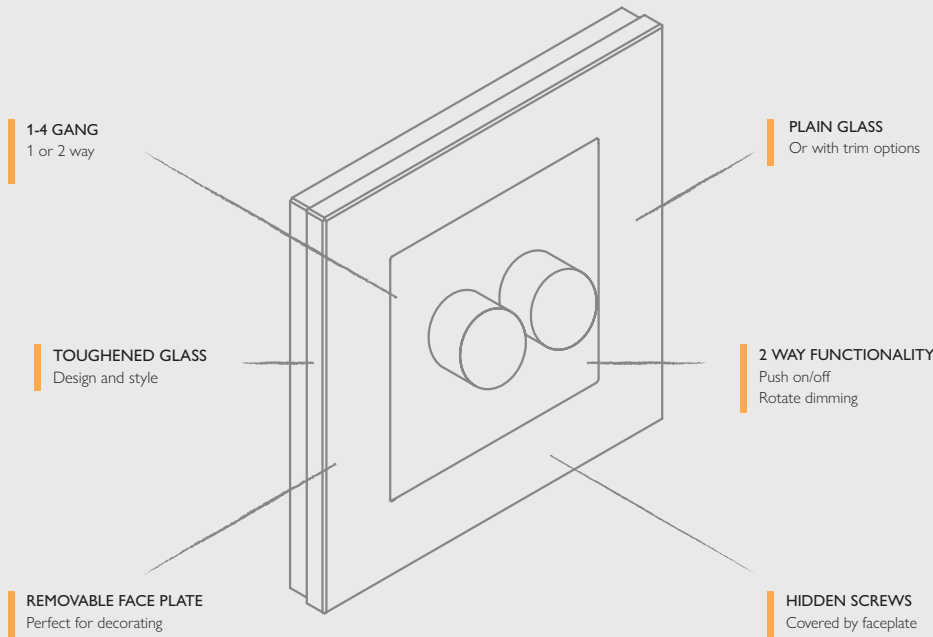

TRAILING EDGE LED DIMMING

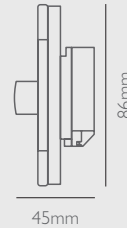
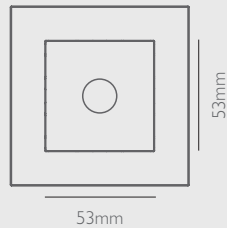
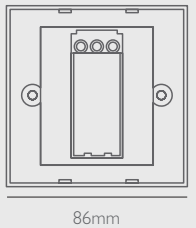

Features

Screwless fronts

The screws are hidden giving your switch a seamless design

Fits 25mm back box

Offers quick and easy installation

Maximum compatibility

Multi-use, compatible with a variety of loads: incandescent, lv halogen and led dimmable lamps and all dimmer switch plates.

Extend lamp life

Soft start operation to prolong the life of the lamp and dimmer.

Functionality

Push on/off for 2-way functionality with rotary dimming.

Dual dimming modes

Leading and trailing edge modes: for electronic transformers, integral dimmable led lamps, iron-core transformers, motor loads and more.

Intelligent setup

Set min/max brightness settings to prevent flicker or flashing for a perfect dimming experience.

Specifications

1-4 gang (1 or 2 way)

1-2 gang 86 x 86mm (standard single)

3-4 gang 146 x 86mm (standard double)

Max load rating: LED lamps max. 150w (max. 10 lamps)

Max load rating: halogen lamps max 400w

Trailing edge/leading edge

Works with LEDs, halogens and standard bulbs

Rated voltage: 220~240v ac (50Hz)

Operating power: 3w - 200w *

Working temperature: 0°C~40°C

Relative humidity: 10% - 93%

Please check led lamp compatibility

Note: 1-10 dimmable LED lamps (max. 120w)

What's in the box

Back plate with Module

Glass front plate in Black or White finish

2 screws for back box fixing

Instruction manual

Certifications

5-year warranty

Ce & RoHS certified

MODELS & FINISHES

ONE GANG



ONE WAY / TWO WAY

PG: 02042-SM 02043-SM

CT: 02040-SM 02041-SM

TWO GANG



ONE WAY / TWO WAY

PG: 02062-SM 02063-SM

CT: 02060-SM 02061-SM

THREE GANG



ONE WAY / TWO WAY

PG: 02082-SM 02083-SM

CT: 02080-SM 02081-SM

FOUR GANG



ONE WAY / TWO WAY

PG: 02102-SM 02103-SM

CT: 02100-SM 02101-SM

ALSO AVAILABLE

DIMMER PLATES ADD YOUR OWN MODULES



ONE TO FOUR GANG PLATES

*Retro*touch[®]
SOCKETS

POWER & CHARGE.



CRYSTAL

NEW

DOUBLE SOCKET WITH USBC

WITH A TOUCH OF GLASS™



DETAILS MATTER.

We're proud to present our new Retrotouch designer USBC sockets. Those with an eye for detail will appreciate the fact that we've carefully created a matching USBC socket for every light switch and wiring accessory in our range.

We offer options with chrome trim or plain glass and all of our USB sockets are screwless. If you are looking for a double socket with extra functionality, we have the perfect item for you.



SPECIFICATIONS / FEATURES

The elegant selection of USBC sockets match the rest of our Crystal range and brings an ideal finish to any interior. Only available in double socket models.

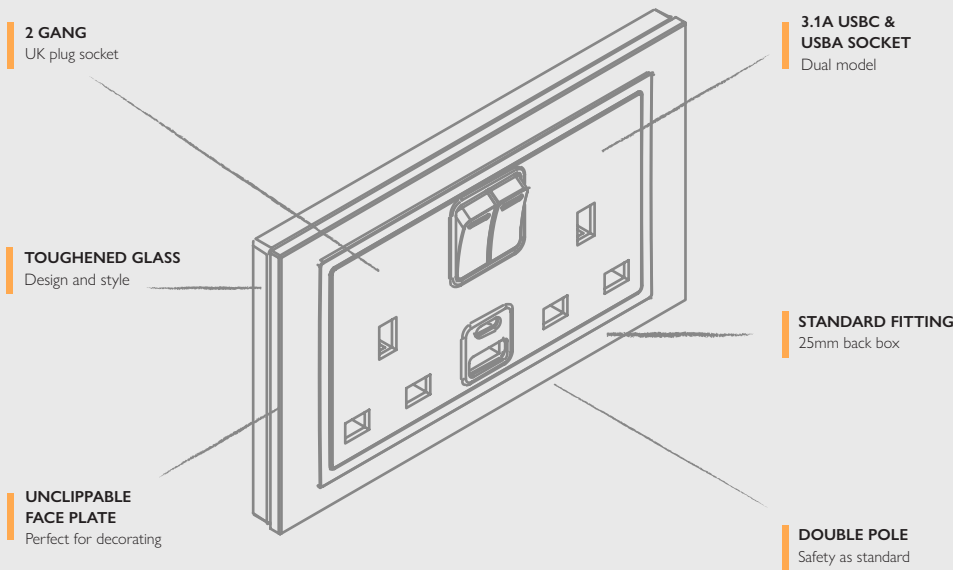

POWER IT IN STYLE.

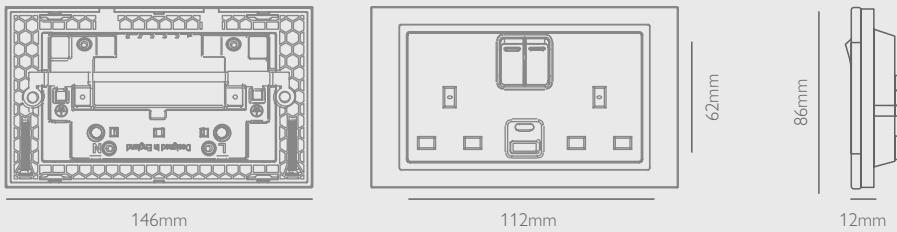

Features

Sophisticated glass finish

Adding a touch of glass for the ultimate finish

Dual USB model

Free up your sockets with one USBA and USBC ports

Screwless fronts

The screws are hidden giving your switch a seamless design

5-year warranty

We've got you covered

Fits 25mm back box

Offers quick and easy installation

Specifications

- 2 gang switched UK plug socket
- 146 x 86mm (standard double)
- Double pole
- 13 amp rated
- Short circuit & overload protection
- Input voltage: 220-240v ac (50/60hz)
- Glass surround with chrome trim
- Concealed fixing screws
- Fits in 25mm depth backbox
- 5V 3.1A USB output (Type C / Type A)

What's in the box

- USB Double Socket
- Glass front plate in Black or White finish
- 2 screws for back box fixing
- Instruction manual

Certifications

- 5-year warranty
- BS1363, BS5733, BS62368, CE & RoHS certified

MODELS & FINISHES

WHITE PG



USBC PLAIN GLASS SOCKET

PG: 00662

WHITE CT



USBC CHROME TRIM SOCKET

CT: 00658

BLACK PG



USBC PLAIN GLASS SOCKET

PG: 00659

BLACK CT



USBC CHROME TRIM SOCKET

CT: 00663

Scan the QR code to view our new USBC sockets product page.



CRYSTAL[®]

UNSWITCHED SOCKETS

WITH A TOUCH OF GLASS™



DESIGN & FUNCTION

Retrotouch also provides a range of stylish unswitched sockets, with screwless fronts matching the same modern glass that is used throughout our Crystal products. Our sockets are available with conventional British plugs, as well as EU styles and multifunction versions.

We offer options with chrome trim or full glass and all of our plug sockets are screwless. Whether you need a single socket or a standard switched dual socket, we have the perfect item for you.



PLUG SOCKETS

UK, EUROPEAN AND INTERNATIONAL

5A ROUND
PIN SOCKET



PG: 04002 04004
CT: 04001 04003

13A SINGLE
UNSWITCHED SOCKET

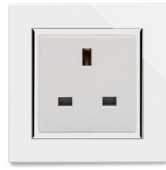

PG: 04042 04044
CT: 04041 04040

16A SINGLE
SCHUKO SOCKET



PG: 04022 00595
CT: 00180 00181

DUAL DOUBLE 13A
PLUG SOCKET



PG: 00656 00654
CT: 00655 00653

SHAVER SOCKET
110V/220V



PG: 00286 00288
CT: 00285 00287

13A SOCKET &
DUAL USB



PG: 00642 00643
CT: 00640 00641

DOUBLE SCHUKO
SOCKET



PG: 04029 00590
CT: 04028 04027

SINGLE MULTI
SOCKET*

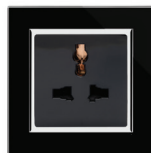

PG: 04032 04034
CT: 00270 00271

*NOT TO BE USED IN THE UK

16A MULTI* &
SCHUKO SOCKET



PG: 04052 04053
CT: 04050 04051

FOR SPECIFICATIONS VISIT OUR WEBSITE

*Retro*touch®
WIRING ACCESSORIES

WITH A TOUCH OF GLASS™



CRYSTAL+ SMART WI-FI SHUTTER SWITCHES



WITH A TOUCH OF GLASS™

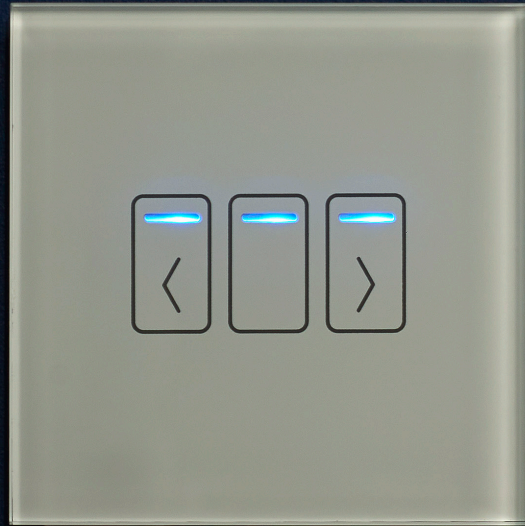

CONTROL YOUR CURTAINS & BLINDS.

Retrotouch Crystal Wi-Fi Shutter Switches are available in four different colours and have backlit LED indicators built-in so you can easily locate your switches at night. Whether your refurbishing or renovating, make your home smarter and up-to-date with our touch-sensitive shutter switches.

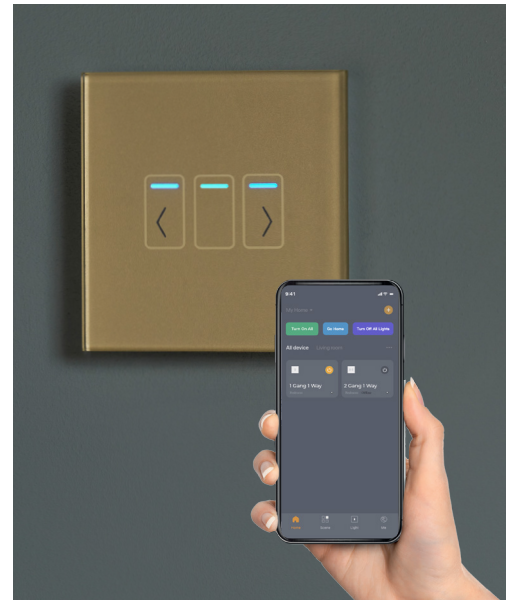

SPECIFICATIONS / FEATURES

Our Crystal Shutter switches control blinds and shutters and have a stunning LED indicator to bring your home up to date. These screwless covers are easy to install and fit a 35mm back box.

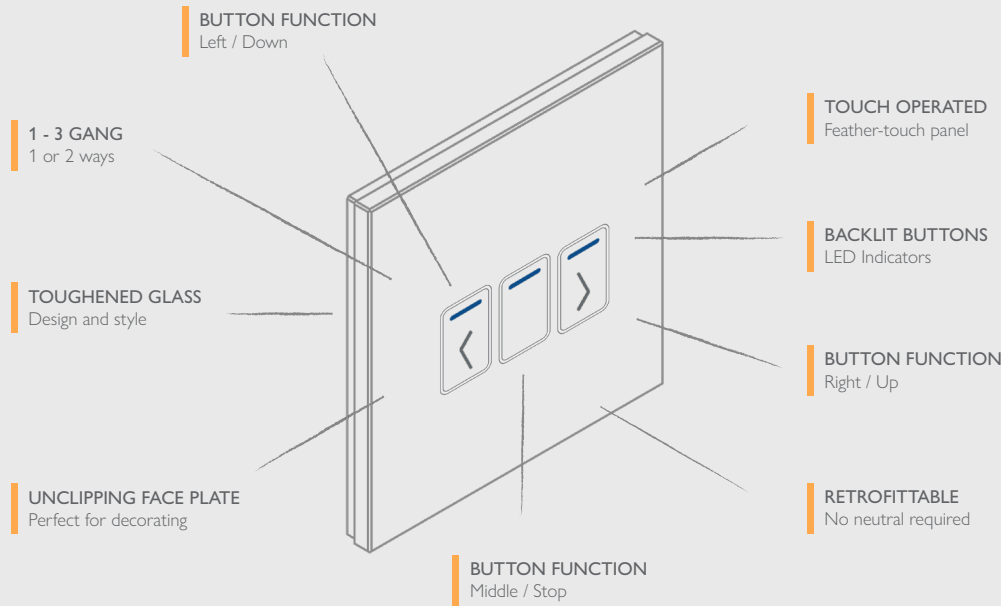

TOUCH AND APP CONTROL.

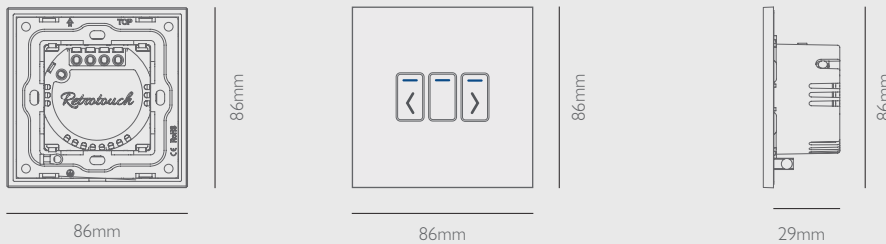

Features

Sophisticated glass finish

Adding a touch of glass for the ultimate finish

Touch Operation

Feather-touch panel with only the slightest of touches needed to turn on and off

Backlit LED indicators

The indicators glow blue when off and red when on for locating your switches in the dark

Fits 35mm back box

Offers quick and easy installation

Screwless fronts

The screws are hidden giving your switch a seamless design

Ultra-thin 4mm glass panel

Low profile panel that sits flush on your wall

Works with

Blinds and Curtains

What's in the box

Back plate with Module

Glass front plate in Black, White, Grey & Brass finish

2 screws for back box fixing

Instruction manual

Specifications

Voltage: 110 ~ 240V ~ 50/60HZ

Working Temperature: 0oC ~ 40oC Relative

Humidity: 10% - 93%

Energy Consumption: <0.02W

Measurement: 86 x 86 x 29mm

Backbox depth: 35mm

Life: 100,000 touches

Power Supply: 100 - 240V AC 50/60HZ

Load Power: 3 - 800W/G (2000W Max)

*Not all LED bulbs are compatible and depends on brand, please call for more information.

Certifications

2-year warranty

CE & RoHS certified

MODELS & FINISHES

WHITE PG TOUCH



ONE GANG

1G: 01490

BLACK PG TOUCH

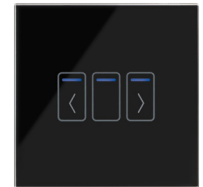

ONE GANG

1G: 01491

GREY PG TOUCH



ONE GANG

1G: 01492

BRASS PG TOUCH



ONE GANG

1G: 01493

Scan the QR code to view our new Touch Switch product page.



CRYSTAL®



FUSED SPUR

WITH A TOUCH OF GLASS™



THE BEST LOOKING SPUR ON THE MARKET.

Our patented Crystal 13A DP switched fused spur/Flex outlet models are designed to provide excellent quality while fitting the aesthetic of your household without the need to visually see the fuse holder.

Boasting a pristine glass exterior, this product perfectly complements the rest of our Crystal range to bring a consistent style throughout your home.



SPECIFICATIONS / FEATURES

Our patented fused spur models are designed to offer outstanding functionality while maintaining the exquisite style of our Crystal range, earning their place as the best looking fuse spur on the market.

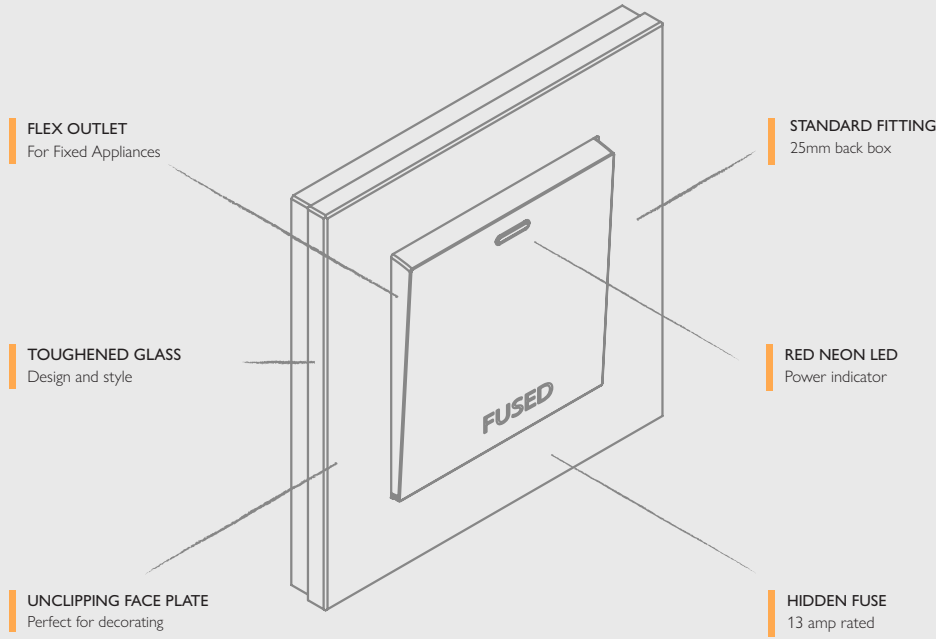

PATENTED TECHNOLOGY.

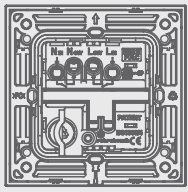

86mm

86mm

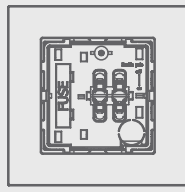

53mm

53mm

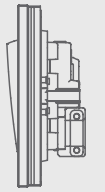

35mm

86mm

Features

Sophisticated glass finish

Adding a touch of glass for the ultimate finish

Concealed Fuse Location

Hidden behind the front plate for a clean look

Screwless fronts

The screws are hidden giving your switch a seamless design

Large easy press buttons

Providing ease of use while keeping a premium look

Fits 25mm back box

Offers quick and easy installation

10-year warranty

We've got you covered

Specifications

Fused spur with switch

Red neon LED

13 amp rated

Flex outlet push through port

Glass surround

Concealed fixing screws

86 x 86mm (standard single)

Fits in 25mm depth backbox

Patented design

What's in the box

Fused Spur

Glass front plate in Black or White finish

2 screws for back box fixing

Instruction manual

Certifications

10-year warranty

CE & RoHS certified

MODELS & FINISHES

FUSED SPUR



WHITE CHROME TRIM

CT:  01760

FUSED SPUR



WHITE PLAIN GLASS

PG:  01761

FUSED SPUR



BLACK CHROME TRIM

CT:  01762

FUSED SPUR



BLACK PLAIN GLASS

PG:  01763

For videos & image gallery visit our website.



CRYSTAL®



COOKER SWITCH

WITH A TOUCH OF GLASS™



DESIGN MEETS FUNCTION

These stylish Crystal Cooker Switch & Sockets boast the screwless glass faceplate characteristic of our Crystal range. The elegant selection of cooker sockets match the rest of our Crystal range and brings an ideal finish to any kitchen. Complement our range of light switches with this stunning yet minimal Cooker socket.



Retrotouch

+44 (0) 1293 279 426 | Sales@retrotouch.co.uk | Retrotouch.co.uk

SPECIFICATIONS / FEATURES

Our new cooker switches combine functionality with the style established through our Crystal range of sockets and switches. Typically an overlooked switch, we're keen to make every switch and socket something you'd want to have on display.

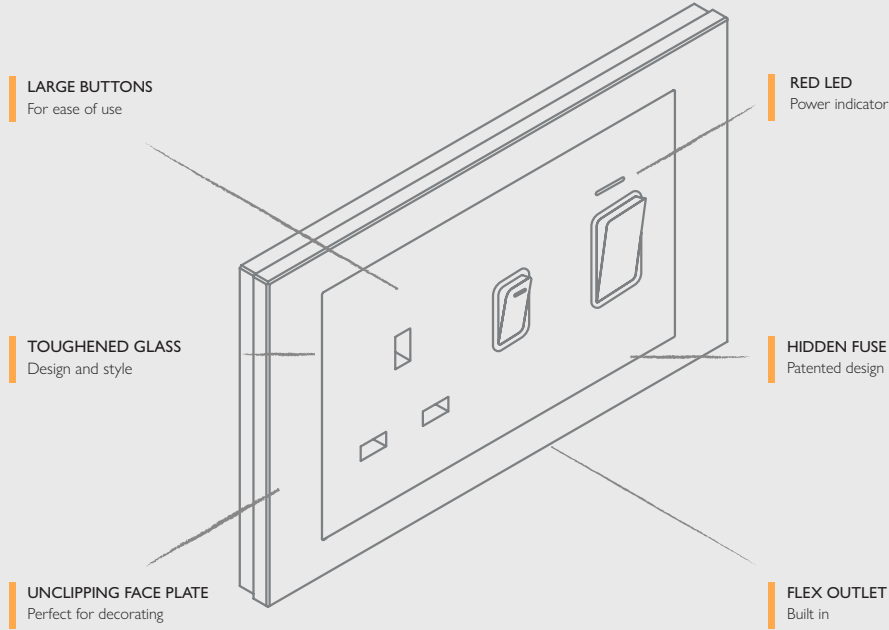

DETAILS MATTER.

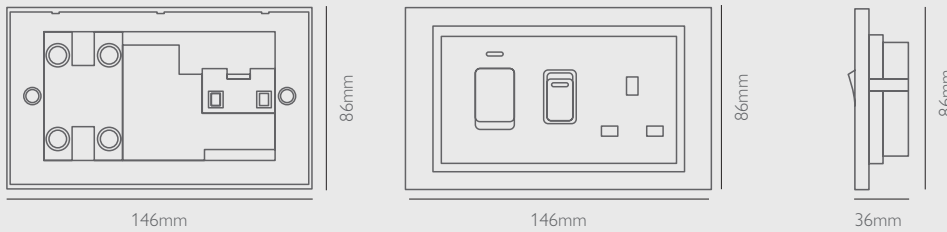

Features

- Sophisticated glass finish**
Adding a touch of glass for the ultimate finish
- Screwless fronts**
The screws are hidden giving your switch a seamless design
- Large easy press buttons**
Providing ease of use while keeping a premium look
- Fits 25mm back box**
Offers quick and easy installation
- 10-year warranty**
We've got you covered

Specifications

- Fused spur with switch
- Red neon
- 13 amp rated
- Flex outlet
- Glass surround
- Concealed fixing screws
- 86 x 86mm (standard single)
- Fits in 25mm depth backbox
- Patented design

What's in the box

- Back plate with Module
- Glass front plate in Black or White finish
- 2 screws for back box fixing
- Instruction manual

Certifications

- 10-year warranty
- CE & RoHS certified

MODELS & FINISHES

COOKER SWITCH



PLAIN GLASS

PG: 01842 01843

COOKER SWITCH



CHROME TRIM

CT: 01840 01841

For videos & image gallery visit our website.





ISOLATOR SWITCHES

WITH A TOUCH OF GLASS™





FAN ISOLATOR



PG:  01730  01732
 CT:  01731  01733





UNSWITCHED FUSED SPUR



PG:  04321  04324
 CT:  04320  04322



20A SWITCH



PG:  01721  01726
 CT:  01720  01725

45A SWITCH



PG:  01711  01716
 CT:  01710  01715



SAFETY AND POWER

Our Crystal range isolator models are designed to provide excellent quality while fitting the aesthetic of your household. Boasting a pristine glass exterior, this cooker switch perfectly compliments the rest of our Crystal range to bring a consistent style throughout your home.



TV, PHONE & AV SOCKETS

WITH A TOUCH OF GLASS™

TV SOCKET



PG: 04077 04079
 CT: 04351 04078

TV & CAT6 SOCKET



PG: 04238 04239
 CT: 04240 04241

TELEPHONE BT SLAVE SOCKET



PG: 04087 04089
 CT: 04086 04088

MEDIA SOCKET TV/RADIO/TWIN SAT/ TV / BT MASTER



PG: 04311 04312
 CT: 04310 04313

DUAL CAT6 SOCKET



PG: 04229 04228
 CT: 04226 04227

TELEPHONE BT MASTER SOCKET



PG: 04082 04084
 CT: 04081 04083

TRIPLE RCA PLATE



PG: 00297 00298
 CT: 00295 00296

3.5MM JACK/AUDIO SOCKET



PG: 00292 00293
 CT: 00290 00291

BRISTLE SOCKET



04097 04099
 04096 04098

FOR FULL RANGE VISIT OUR WEBSITE



INTELLIGENT DIMMER MODULE

WITH A TOUCH OF GLASS™



07247

LEADING & TRAILING EDGE

For maximum flexibility, we also offer our LED dimmer module and dummy on/off modules to use with your existing plates and to create a combination of dimmer and On/Off switches on one plate.

AUTO CONFIGURING

LED DIMMER PLATES

WITH A TOUCH OF GLASS™



ONE GANG

- PG: 02052 02053
- CT: 02050 02051



TWO GANG

- PG: 02072 02073
- CT: 02070 02071



THREE GANG

- PG: 02092 02093
- CT: 02090 02091



FOUR GANG

- PG: 02112 02113
- CT: 02110 02111

Set the mood for your home with our dimmer plates. Our plates boast a premium glass design with a smoothly adjustable dimming knob. Furnished with a sleek glass exterior and very easy to install, our rotary dimmer plates are perfect for setting the right ambience for your home.

Rotary Dimmer Plate With Knob Only

1-4 Gang

Does Not Include Dimmer Modules

Plain Glass Surround Models

Chrome Trim Finishes

Concealed Fixing Screws

5 Year Warranty

Ce & Rohs Certified

OUR PLATES WORK WITH ANY DIMMER MODULE



USE ANY BRANDS DIMMER MODULE

↓

ADD TO RETROTOUCH DIMMER PLATE



LED INTELLIGENT DIMMER MODULE 5-150W



Features

Maximum compatibility

Multi-use, compatible with a variety of loads: incandescent, lv halogen and led dimmable lamps and all dimmer switch plates.

Extend lamp life

Soft start operation to prolong the life of the lamp and dimmer.

Functionality

Push on/off for 2-way functionality with rotary dimming.

Dual dimming modes

Leading and trailing edge modes: for electronic transformers, integral dimmable led lamps, iron-core transformers, motor loads and more.

Intelligent setup

Set min/max brightness settings to prevent flicker or flashing for a perfect dimming experience.

Safety at heart

Auto thermal and overload protection to protect the circuit.

Specifications

Rotary intelligent dimmer (module only)

Retrofit solution (uses existing wiring)

Max load rating: LED lamps max. 150w (max. 10 lamps)

Max load rating: halogen lamps max 400w (1 or 2 way)

Trailing edge/leading edge

Push on/off

Intelligent dimming setup

Works with LEDs, halogens and standard bulbs

23mm depth

Rated voltage: 220~240v ac (50hz)

Working temperature: 0°C~40°C

Relative humidity: 10% - 93%

What's in the box

Intelligent dimmer module

Instruction manual

Certifications

5-year warranty

Ce & RoHS certified

Please check led lamp compatibility

FLICKER-FREE GUARANTEE.

We're confident our dimmers work with 99% of lamps in the market. If it doesn't, we will give you a full refund and help you find a dimmer module suitable for your lamp.

For videos & image gallery visit our website.



CRYSTAL®

EURO PLATES & EURO MODULES

WITH A TOUCH OF GLASS™



PICK AND MIX.

Create wiring plates with exactly the modules you need for the perfect customised wiring accessory.

In white & black with every wiring accessory imaginable, using modules you can create a plate to your exact requirements. If you can't see the module you require, just contact our sales team.



+



=





CUSTOM PLATE CONFIGURATION

PICK YOUR PLATE.



WHITE CT



WHITE PG



BLACK CT



BLACK PG

PLATES FIT ANY EURO STANDARD
25 X 50MM OR 50 X 50MM MODULES



ADD YOUR MODULES.



5A SOCKET



13A SOCKET



16A SOCKET



SHUKO SOCKET



10A SWITCH



20A SWITCH



FUSE



RJ11 SOCKET



MULTI SOCKET



USB SOCKET



DOUBLE BLANK



SINGLE BLANK



BT MASTER



BT SLAVE



CAT5



CAT6



SPEAKER POSTS



AUX SOCKET



AUDIOVIDEO



HDMI SOCKET



TV SOCKET



SAT - F TYPE



MEDIA MODULE



BRUSH PLATE

*Retro*touch®

PREMIUM SWITCHES & SOCKETS

SIMPLICITY™



SIMPLICITY™



ROCKER LIGHT SWITCHES

PREMIUM SWITCHES & SOCKETS



MODERN. SOPHISTICATED.

Our fantastic mechanical rocker light switches are now available in a high quality & durable plastic finish.

With a sleek, modern design, these switches are the ideal choice for a contemporary home. They come with large, easy press buttons and screwless fronts, creating a streamlined and sophisticated look in any room. At Retrotouch we think the smallest details make the largest difference.



These Simplicity Rocker Light Switches are a sophisticated way to revitalise the light switches in your home and modernise any interior.

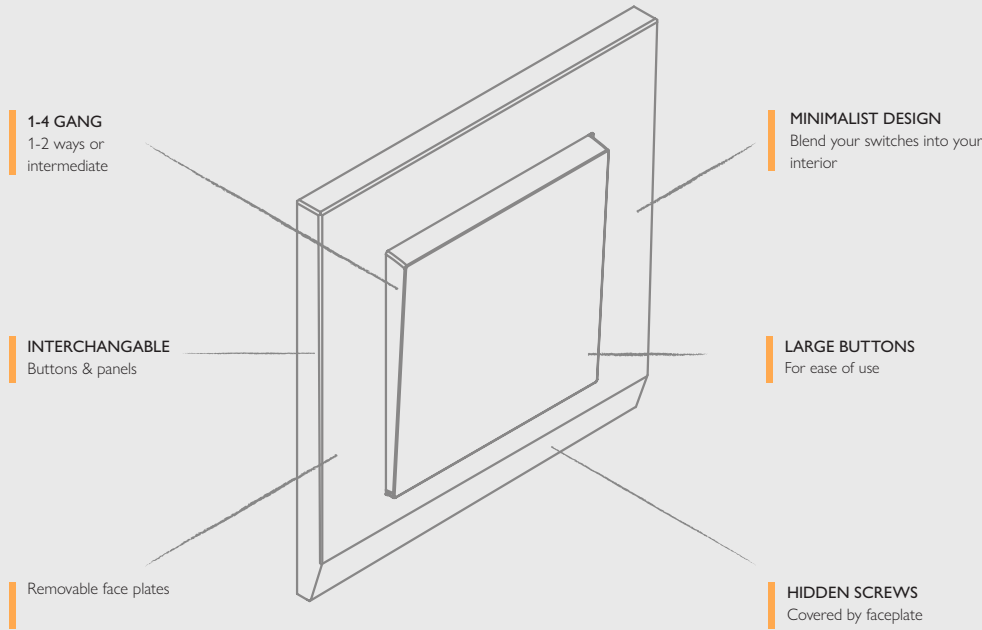

INTERCHANGABLE COVERS.

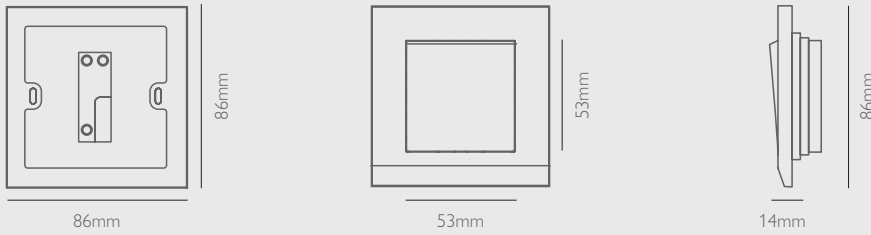

Features

Modern and sophisticated design
An ideal choice for a contemporary home

Screwless fronts
The screws are hidden giving your switch a seamless design

Large easy press buttons
Providing ease of use while keeping a premium look

Fits 25mm back box
Offers quick and easy installation

Specifications

- Rocker switch
- Interchangeable surround
- Large easy press button(s)
- 1-4 gang (1 or 2 ways)
- 1-2 gang (Intermediate)
- 10 amp rated
- Material: plastic (PC)
- Concealed fixing screws
- Fits in 25mm back box

What's in the box

- Back plate with Module
- Glass front plate in Black or White finish
- 2 screws for back box fixing
- Instruction manual

Certifications

- 10 Year Warranty
- BS60669
- CE & RoHS Certified

ONE GANG



ONE WAY / TWO WAY

WHITE: 07000

INTERMEDIATE

WHITE: 07140

TWO GANG



ONE WAY / TWO WAY

WHITE: 07020

THREE GANG



ONE WAY / TWO WAY

WHITE: 07040

FOUR GANG



ONE WAY / TWO WAY

WHITE: 07060

ALSO AVAILABLE
PART-M VERSIONS
MAKING IT EASIER FOR
PEOPLE WITH A DISABILITY



ONE TO FOUR GANG PLATES

SIMPLICITY™



ROTARY DIMMER SWITCHES

INTELLIGENT DIMMERS



LIGHTS. DIM. ACTION.

Retrotouch's dimmer switch collection features a premium glass design, making your home both timeless and elegant. The switches are suitable for dimming LED and conventional bulbs and they use the latest in trailing edge dimming technology to create that 'just so' ambience to any interior.

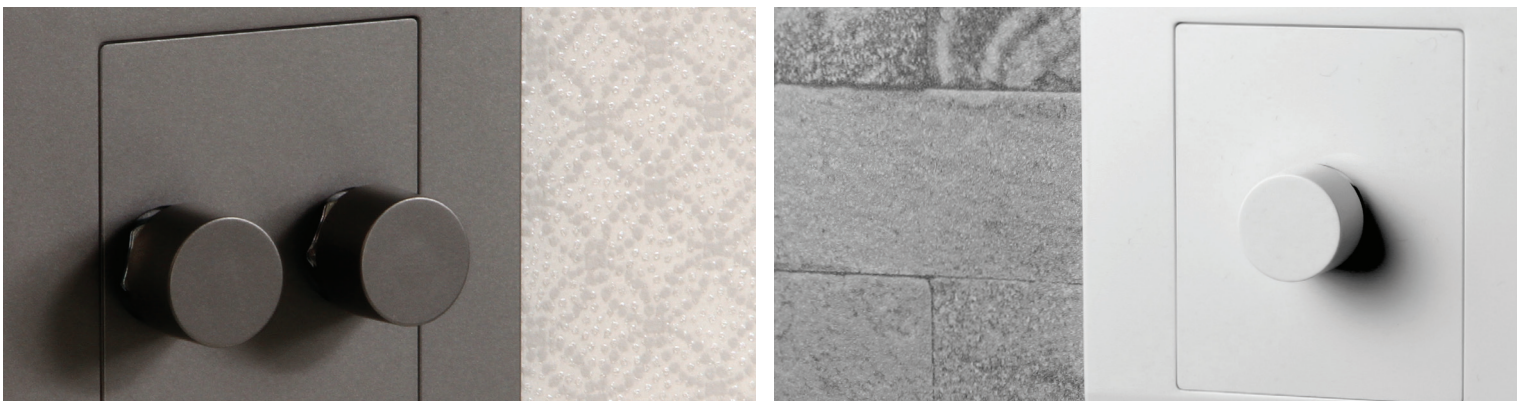

These Crystal Rocker Light Switches are a sophisticated way to revitalise the light switches in your home and modernise any interior.

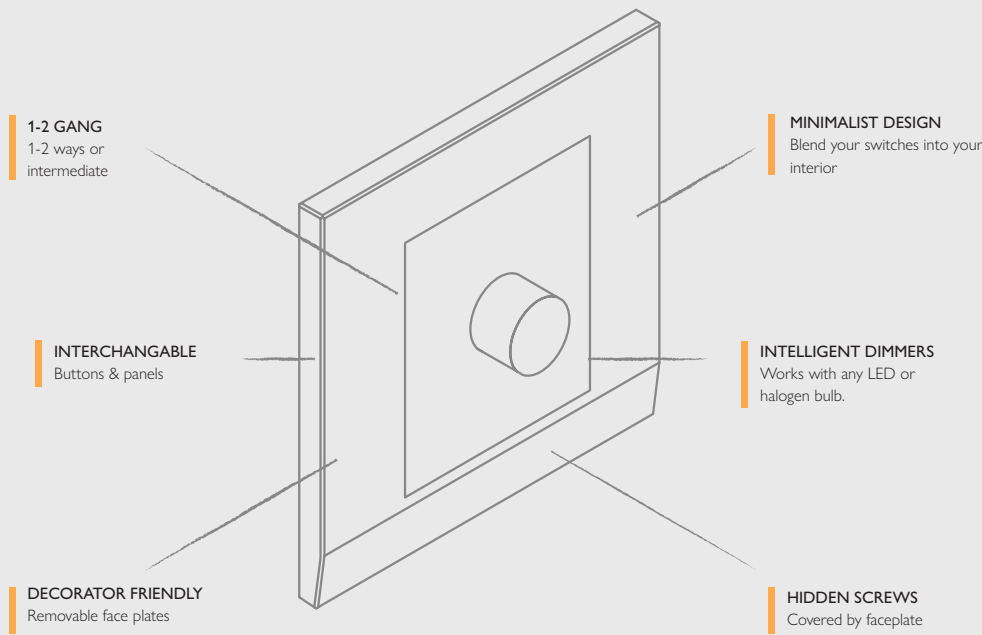

FLICKER FREE DIMMING.

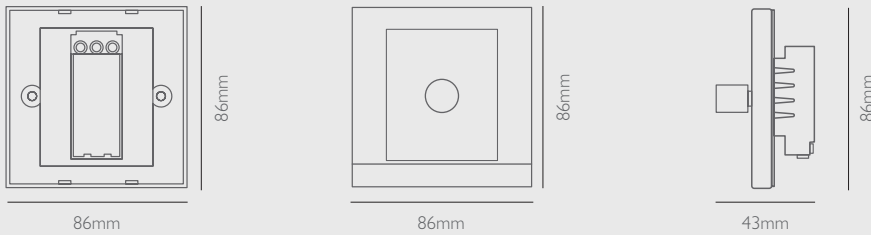

Features

Modern and sophisticated design
An ideal choice for a contemporary home

Screwless fronts
The screws are hidden giving your switch a seamless design

Large easy press buttons
Providing ease of use while keeping a premium look

Fits 25mm back box
Offers quick and easy installation

Specifications

- Trailing edge
- Push on/off
- Potentiometer to vary dimming level
- Interchangeable Surround
- Material: Plastic (PC)
- Works with LEDs, Halogens and standard bulbs
- Rated Voltage: 220~240V AC (50/60Hz)
- Operating Power: 3W - 200W
- Working Temperature: 0°C~40°C
- Relative Humidity: 10% - 93%
- Note: 1-10 Dimmable LED lamps (max. 120W) per gang
- Halogen Lamps (Max 200W) per gang

What's in the box

- Back plate with Module
- Front plate in Black or White finish
- 2 screws for back box fixing
- Instruction manual

Certifications

- 5-year warranty
- Ce & RoHS certified

ONE GANG



ONE WAY / TWO WAY

WHITE: 07251-SM

MID GREY: 07253-SM

TWO GANG



ONE WAY / TWO WAY

WHITE: 07220-SM

MID GREY: 07222-SM

For videos & image gallery visit our website.



SIMPLICITY™



PLUG SOCKETS

SCREWLESS DESIGN



DETAILS MATTER.

Our outstanding Simplicity 13A double switched sockets are now available in a high-quality and durable plastic finish. With a sleek, modern design, these sockets are the ideal choice for a contemporary home. They come with screwless fronts, creating a streamlined and sophisticated look in any room.

At Retrotouch we think the small details make the biggest difference.



SPECIFICATIONS / FEATURES

The elegant selection of electric sockets match the rest of our Crystal range and brings an ideal finish to any interior.

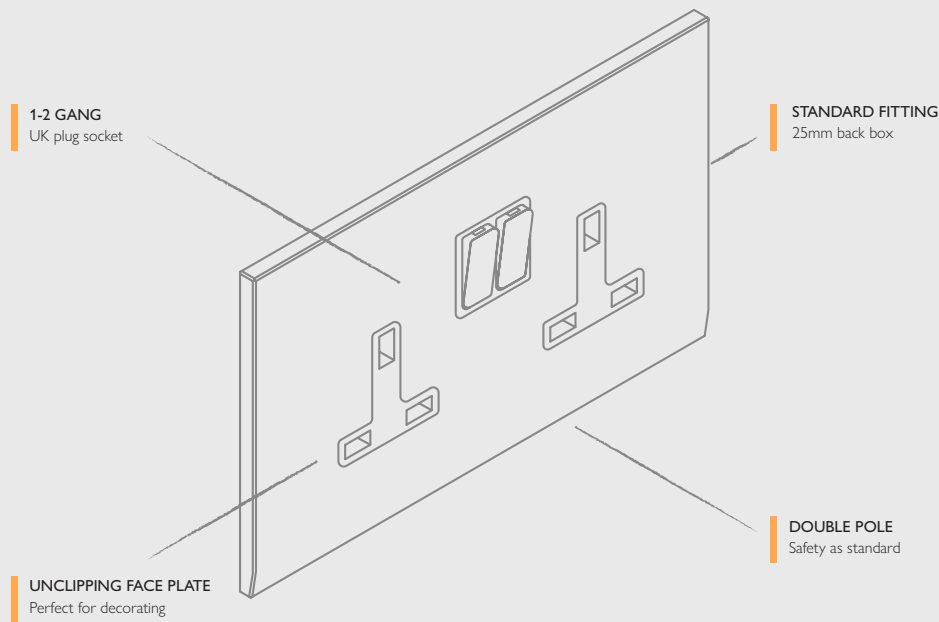

A TOUCH OF DESIGN.

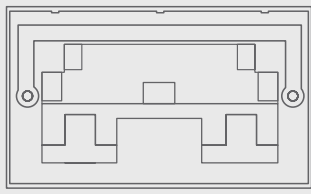

146mm

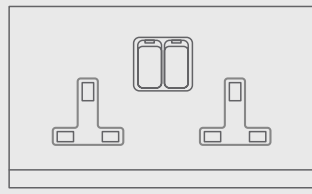

146mm

86mm



30mm

86mm

Features

Sophisticated glass finish

Adding a touch of glass for the ultimate finish

Screwless fronts

The screws are hidden giving your switch a seamless design

10-year warranty

We've got you covered

Fits 25mm back box

Offers quick and easy installation

Specifications

2 gang switched UK plug socket

Double pole

13 amp rated

Interchangeable surround

Material: plastic (PC)

Concealed fixing screws

146 x 86mm (standard double)

Fits in 25mm depth backbox

What's in the box

Back plate with Module

Front plate in Black or White finish

2 screws for back box fixing

Instruction manual

Certifications

10-year warranty

BS1363

CE & RoHS certified

MODELS & FINISHES

TWO GANG



13A DP SOCKET

WHITE: 07440



MID GREY: 07442



ONE GANG



13A DP SOCKET

WHITE: 07320



MID GREY: 07322



ONE GANG + USB



13A DP SOCKET

WHITE: 07360



MID GREY: 07362



For videos &
image gallery
visit our
website.



SIMPLICITY™

ISOLATOR SWITCHES

WITH STYLE AND SUBSTANCE

FAN ISOLATOR



08010 08012

SWITCHED FUSED SPUR



07820 07822

UNSWITCHED FUSED SPUR



07800 07802

20A SWITCH



07260 07262

45A SWITCH



07300 07302

BLANK PLATES



07840 07842



WIRING ACCESSORIES

FOR THE WHOLE HOME

TV SOCKET



07560 07562

TV AND SATELLITE



07620 07622

BT SLAVE SOCKET



07760 07762

TV / FM SOCKET



07600 07602

F TYPE SOCKET
TV/RADIO/TWIN SAT/ TV / BT MASTER



07640 07642

DOUBLE CAT5E SOCKET



07680 07682

SHAVER



08030 08032

FLEX OUTLET



07780 07782

BT MASTER SOCKET



07740 07742

FOR FULL RANGE OF ACCESSORIES VISIT OUR WEBSITE

SIMPLICITY™

HOTEL ROOM SWITCHES

IMPRESS YOUR GUESTS



LIGHTS. DIM. ACTION.

A great value option for hotel projects but also for people wanting multi plates by the bedside or behind the TV. This Pick and Mix solution gives maximum flexibility to create plates with any combination on a budget. Simply pick your wiring accessories and combine together with a single plate.





HOTEL PLATE CONFIGURATION

PICK YOUR PLATE.

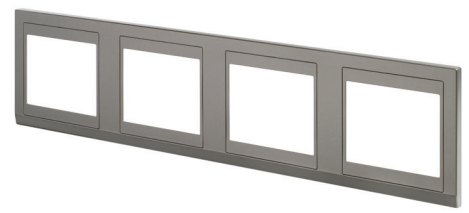
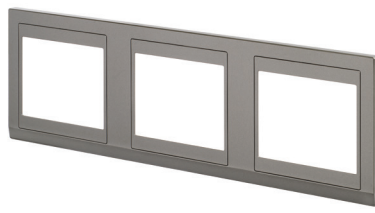

MID GREY



WHITE



ADD ANY SIMPLICITY SWITCH OR ACCESSORY



ROCKER SWITCH



13A SOCKET



FUSED SPUR



CAT5E SOCKET



DIMMER SWITCH



TV / SATELLITE



FAN ISOLATOR



FLEX OUTLET



**FREE COLOUR
SAMPLES**

[RETROTOUCH.CO.UK/
COLOUR-SAMPLES](https://retrotouch.co.uk/colour-samples)

**FIND A
LOCAL RETAILER**

[RETROTOUCH.CO.UK/
WHERE-TO-BUY](https://retrotouch.co.uk/where-to-buy)



RETROTOUCH.CO.UK

sales@litheaudio.com | Live Chat | Tel : +44 (0) 1293 922 015

RETROTOUCH IS LISTED ON:
LUCKINS™